

ALPHA XT



ALPHA_{SERIES}

The World's Finest CNC Combination Lathes

MT/XS/XM

The Ultimate Turning Machines



The Alpha Series – offers the widest variety of control levels from manual through full ISO on one machine. Tailored to optimize the skill level of the machine operator, the Alpha Series offers a large machine envelope for the efficient production of a wide variety of components in small to medium size batches.

Our aim is to provide precision metal cutting lathes of the highest quality at affordable prices. This four machine range is perfect for producing high quality, detailed and intricate one-offs and small to medium sized batches.

Alpha XT: The Alpha XT comes with the latest Fanuc 0i Mate-TC control coupled with the Turnmate *i* conversational programming package for the super quick drawing to machining times. This machine gives the operator the option of manual or automatic turning which means that the Alpha XT is the most capable machine in its class.

Alpha MT Series: This is a four machine range of advanced technology lathes. The MT series features the latest generation Fanuc 0i TC control with color screen, ideal for first time CNC users and for producing medium to short production runs.

Alpha XS Series: The Alpha XS series offers a choice of five advanced technology lathes. The new generation Fanuc 21i TB control with color touch screen and custom software systems give you full CNC capability. They are ideal for turning small-to-medium sized batches with fast, high quality repeatability, excellent accuracy and surface finish and, most importantly of all, lower component production costs.

Alpha 1550XM: Extremely versatile, this machine provides all the features of the Alpha XS with the additional capacity for high precision full C - axis milling as well as turning. This milling option makes it a highly versatile and cost effective machine for a wide range of advanced machining applications.

High Precision Turning Applications

The superb new Alpha Series from Colchester-Harrison offers a choice of twenty three advanced technology CNC Combination Lathes to suit all types of high-precision turning applications. All Alpha Series lathes are perfectly suited to producing detailed and intricate one-offs to the highest standard of finish and accuracy. With their advanced Fanuc control and software systems, they are ideal for turning small-to-large sized batches with fast, high quality repeatability, excellent accuracy and surface finish and, most importantly of all, lower component production costs.

Alpha quality, plus a wide range of training options, has made Alpha lathes the favorite choice for colleges and training centers around the world. Ideal training features include compatibility with industry standard ISO programs and Colchester-Harrison's AlphaLink software which enables multi-desk training to be given.

No other lathes on the market today, including full CNC machines, can compete with Colchester-Harrison's Alpha Series for cost and speed of production when it comes to 'one-offs' and small-batch turned parts.



Machine Bed

Colchester-Harrison's cutting-edge lathe design and construction quality begins with the machine bed. Alpha beds use high quality cast iron, with a unique 'Warren' type design for maximum strength and optimum chip clearance.

In addition, the Alpha lathe bed are mounted on cast-iron base to provide a solid foundation. Slideways are hardened and specially ground to ensure high-precision, parallel operation of the lathe at all times.

Operators Console

The operator's console is located for optimum operator convenience and efficiency directly in line-of-sight with the cutting tool. The hand wheels are installed at the ideal ergonomic height for ease of use and have the Alpha's popular "one-click-one-micron" rotational feel sensitivity.

The complete operator's control panel moves on its own independent carriage which allows it to be moved quickly and effortlessly to the side during loading and setting up.

Market Leading Performance

A Century of Quality and Excellence

Strength, reliability, versatility, ease of operation and accuracy have always been bywords for Colchester-Harrison lathes. This comes from our continuous commitment to develop and enhance our world famous lathes. Today, advanced new technologies are integrated into all Alpha lathes for market leading performance combined with our traditional build quality and durability. In addition, the award winning Alpha 1550XM has the capability for milling as well as turning. This innovative machine introduces an extra dimension especially for customers who have previously invested in separate lathes and milling machines.

It adds up to a formula for lathe construction, which is second to none.

The Ultimate Turning Machines

- Superb cutting performance
- High spindle speeds with wider speed ranges
- Fast rapid traverse rates
- Excellent spindle torque at low speeds
- Latest Fanuc Beta α Series spindle and Beta α s axis motors
- Top rated GAMET ABEC9 high-precision bearings
- Independent, sliding operator's console
- New state-of-the-art Fanuc controls with conversational programming software
- Fast, easy set up - quickest of any lathe on the market
- New style fully enclosed guarding for maximum safety (Single travelling guard on 120"/160" (3/4m) models)
- Automatic slideway and ballscrew lubrication system
- Extended range with up to 160" (3m) between centers
- AlphaLink Windows CAD/CAM offline programming CD and communications cable

Drive Train

Into the design and development of all Alpha lathes goes the technical expertise of specialists from Colchester-Harrison's partner companies, Gamet Bearings and Pratt Burnerd chucking systems. Their combined research programs ensure that all new Alpha lathes feature the most advanced developments in spindle bearing technology and chuck design. This provides the highest possible spindle speeds and optimum chuck performance for high accuracy turning with maximum load carrying capacity.

Headstock

Crucial to turning precision and quality is the design and capability of the headstock. These lathes have top rated Fanuc spindle motors for extra power and more torque in all speed ranges. This means that 'bottom end' torque has been increased by over 75% giving excellent, extremely accurate metal-cutting performance at lower speeds.

All Alpha Series lathes are equipped with three range headstock enabling the correct range to be automatically selected from the lathe's control system.

Alpha XT Range - Fanuc Oi Mate - TC

All Alpha XT lathes are fitted with the latest Fanuc control available on the market today.

The Fanuc Oi Mate TC control gives you the option of manual or automatic operation and includes over 200 standard features including Custom Macro B, Rigid Tapping and 256K Part Program Memory. This control will immediately increase your productivity and will continue to do so year after year.

The manual mode employs Fanuc's latest version of Manual Programming Turn Mate *i* which is acclaimed to be the simplest and most user friendly teach lathe control in the world.

In automatic mode we use Fanuc's powerful CNC interface for the simple generation and execution of ISO programs.

The combination of these two systems on one machine makes the Alpha XT the most capable lathe available in its class.

It will do virtually anything you ask of it!

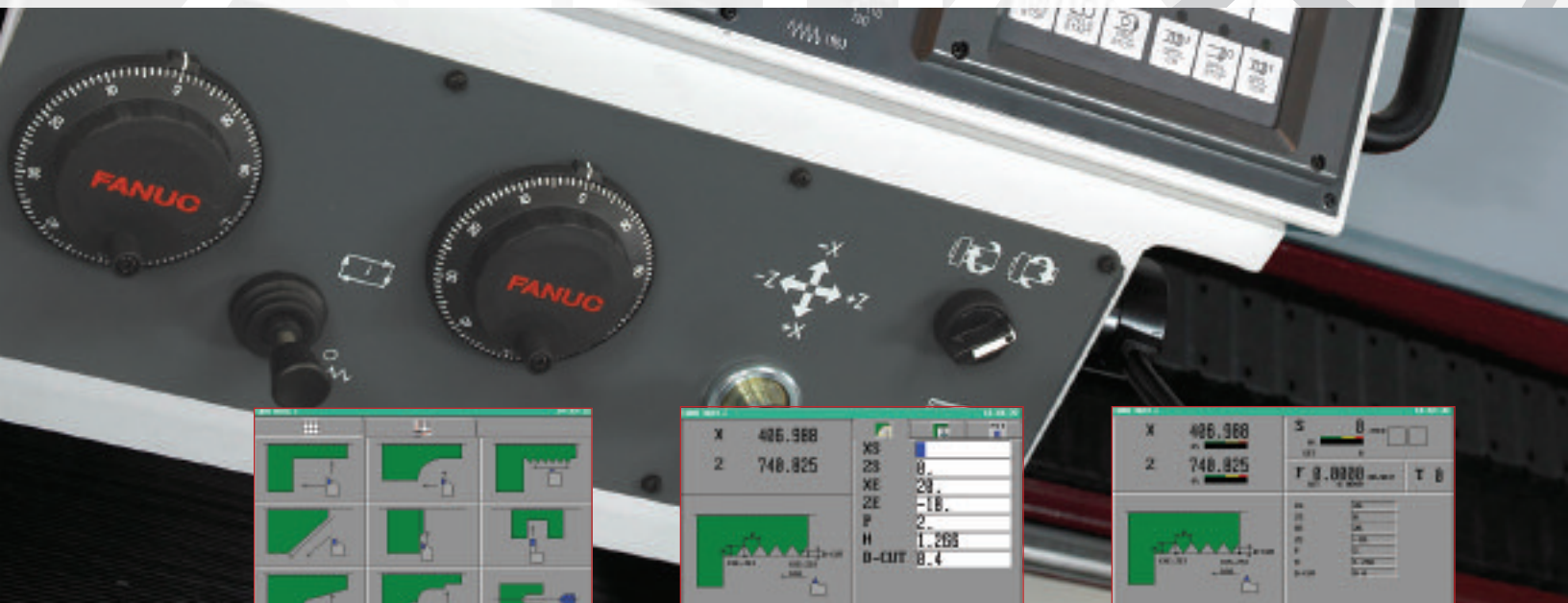

Op. Selection Screen

The Turnmate *i* software contains a full range of conversational cycles, (profile, taper, thread, bore, drill, tap etc.) and for the first time you can program full contour machining at the control. What's more, the easy to understand shop floor language coupled with touch screen simplicity means that any operator can learn to machine parts quickly.

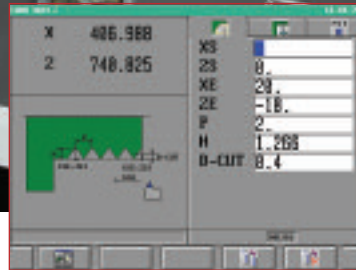

Op. Execution Screen

We use a touch screen so you can work directly on screen rather than spend time looking for the right button to press. This system uses easily recognizable screen graphics along with simple question and answer prompts to guide you. During cycle execution, the current cycle is clearly shown on the screen along with speed, feed, tool and axis positional information.



Data Input Screen

For ease of programming, cycle data is input from a clearly defined input screen with large text and symbols. To retain continuity with previous Alpha T controls, all cycles can be used in semi-manual mode (cut depth selected by hand wheel) by simply omitting the cut depth from the cycle being used.

Most operators will learn how to use this system in less than half a day!

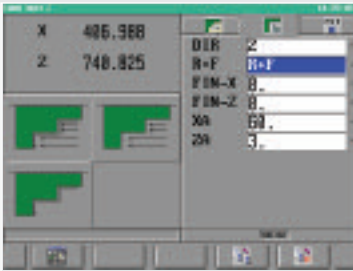

Profile Programming

Complex contours can be easily produced using clear and understandable icons. Contours are generated using simple elements such as line, arc and chamfer commands.



Tool Setting

Tool positions can be easily and quickly set using simple to understand icon driven input screens to assist non-experienced operators.

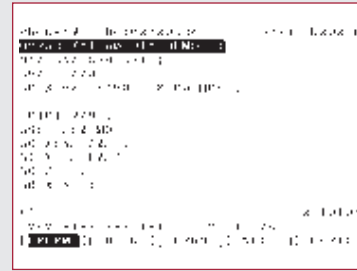

ISO Programming

ISO functionality (CNC) allows experienced operators to run programs previously used on other CNC machines and/or generate new programs themselves. An 8 station automatic turret to be offered as an option enabling full automatic machining.

The Ultimate Turning Machines

Standard Control Features for Alpha XT - Fanuc Oi Mate - TC

- Thread cutting retract
- Continuous thread cutting
- Rigid tapping
- G code system B/C
- Custom macro B
- Additional custom macro variables
- Chamfering corner R and corner radius
- Inch/metric conversion
- Multiple repetitive cycles
- RS232 interface
- Tool offsets, 64 pairs
- Tool geometry/wear compensation
- Background editing
- Machine alarm diagnostics
- Tool path graphics
- Canned cycles for drilling
- Tool nose radius compensation
- CSS Constant Surface Speed
- Stored stroke limit 2/3
- Stroke limit before move
- Direct drawing program
- Run/hour part count
- Part program memory 256 kB
- Chuck and tailstock barrier
- Optional block skip 9
- Workpiece co ordinate system
- Spindle orientation
- Extended part program edit
- Conversational programming with graphics function
- 10 languages available
- Turnmate **i**

Alpha Link CAD/CAM For The Alpha X Range

All Alpha lathes are supplied with free Alphaslink CAD/CAM software, a fully Windows compatible system, which greatly increases the flexibility of the lathe. AlphaLink provides a simple yet powerful CAD/CAM system for off-line programming, G code outputting and mass storage back up of programs for all our models. The software is installed onto your own computer for use in the office or home or link directly to the machine.

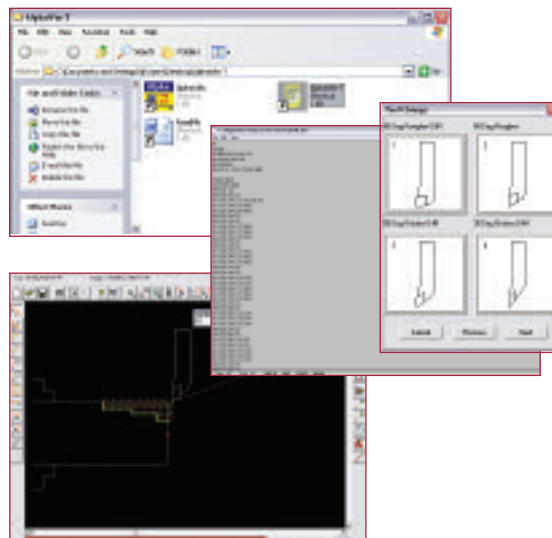

ALPHALINK SOFTWARE

1. SIMPLE TO USE
2. FREE WITH ALPHA XT
3. DESIGNED SPECIFICALLY FOR THE ALPHA XT LATHE
4. FULL COMMUNICATION PACKAGE
5. EASY TO USE ISO EDITOR
6. PACKAGE INCLUDES BOTH SOFTWARE DISC AND CABLE
7. FULL ON SCREEN SIMULATION
8. TOOL LIBRARY
9. FULL RANGE OF DRAWING COMMANDS
10. FULL RANGE OF MACHINING CYCLES
11. PRINT FACILITY
12. CONVERTS DXF (Data Exchange Format) FILES INTO ALPHALINK DRAWINGS

Alpha MT Range - Fanuc Oi TC Control

The highly versatile flat bed design handles a wide range of turning applications: long shafts, bar stock, castings and with the gap removed, large diameter face plate work. Engineered for precision and maximum CNC performance with features found only on high-end CNC lathes.

The Alpha MT is equipped with the latest generation G.E. Fanuc Oi-TC control package with all digital control and drives offers exceptional value and reliability with many standard features to simplify operation and increase productivity.

A wide choice of tooling options are available to further enhance the versatility of the machine. Gang tooling, quick-change tool posts and automatic indexing turrets are available to maximize output in most any situation.

The heavy-duty cast iron machine is ideal for: CNC users looking for increased versatility at a very low capital outlay, First time CNC buyers looking for programming simplicity, Job shops looking for increased output, Low to medium production runs and Education and training facilities needing a real lathe with step-by-step simplicity

The perfect machine for many of today's CNC turning applications...



- Control panel rides on a rail, so the control can be positioned for maximum operator convenience
- Anti-friction PTFE material between saddle and bed greatly reduces friction and has superior dampening properties for chatter free machining. The low friction PTFE material minimizes bed wear and extends machine life
- Heavy-duty cast iron bed ways are induction hardened to 45Rc
- Triangular web bed design provides a very high torsional stiffness, eliminating bed deflection even under heavy cutting conditions
- Extra wide bed maximizes support for saddle and cross slide assembly for smooth machining, even of large workpieces
- Variable AC spindle drive motor for exceptional machining power
- Automatic three range headstock allows full horsepower at low rpm for more efficient machining of parts requiring low spindle speed such as large components or hardened steels
- Superior headstock lubrication system to ensure long spindle bearing and gear life
- Automatic oil system, with low oil alarm, to maintain proper lubrication of slide ways and ballscrews
- Digital AC servo drive system provides powerful and accurate axes positioning
- Fully enclosed, interlocking guarding to maintain a clean work environment
- The compact size of the Alpha MT allows for efficient use of floor space



G.E. Fanuc Oi-TC Control

Latest generation Oi-TC control offers exceptional value and reliability with many standard features to simplify operation and increase productivity.

The Alpha MT range is the first CNC lathe in the world to use the latest full digital G.E. Fanuc Oi-TC control package with 'Manual Guide i' programming software. The operator is able to generate part programs quickly and efficiently through the use of easy-to-understand conversational style cycle prompts.

The G.E. Fanuc Oi-TC is one of the most user-friendly controls in the industry today and is loaded with many standard features to increase your productivity...

- Multi-repetitive Cycles G70-G76 for automatic finishing, roughing, drilling, threading and grooving cycles
- Toolpath Graphics for verification of part profile
- 10.4" Color LCD Display
- Inch/metric data input
- Absolute/incremental programming in the same block
- Thread cutting leads range from 0.00001" to 1.0"
- Threading retract
- Variable lead threading
- Multiple and continuous threading
- Rigid tapping
- Constant surface speed/direct rpm programming
- Menu programming format with operator prompts
- 2 axes linear and circular interpolation
- Sequence number search
- Sequence number comparison and stop
- 128K part program memory
- Background editing
- Extended part program edit
- 64 sets of tool offsets
- 64 sets of tool offsets
- Optional stop/block delete
- Run hour part counter
- Tool nose radius compensation
- Tool geometry/wear offsets
- Tool life management
- Work coordinate system G52-G59
- Automatic reference zero return G28
- Reference position return check G27
- Spindle orientation
- Machine alarm diagnostic
- Absolute encoders
- Manual pulse generator
- RS 232 interface port
- Mirror image
- Turret crash protection
- Dynamic graphic display
- Pattern data input
- Manual intervention and return
- Chuck/tailstock barrier

Creating A Program

1. Press the function key under NEWPRO, the OPEN PROGRAM window will appear.
2. Press the function key under 'CREATE' and you're ready to set up a new part program.
3. Press the function key under START and a 'Starting Command For Turning' window will appear.
4. Press the function key under 'SELECT' and the 'Cylinder Blank' window will appear.
5. Fill in the blanks and press the function key under 'INSERT'
6. Select tool and start point, just fill in the blanks and insert into the program.
7. Press the function key under 'CYCLE' to select a cycle
8. Fill in the blanks and insert into program.
9. Insert 'XZ PLANE TURNING FIGURE' data. Now you are ready to finish your program.
10. To end the program, press the Function Key under 'END'. The 'PROGRAM END INFORMATION' screen will appear, input the 'SAFE END POS.' for X & Z, insert into your program and you're ready to go.

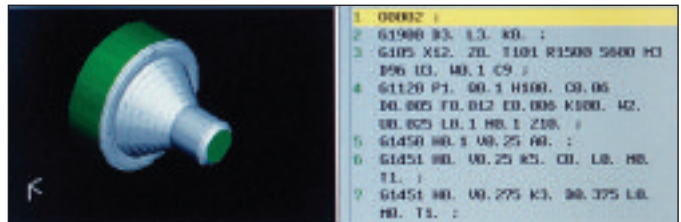

Check your part program in the 'SIMULATE' window, you can view a 3-D image of the finished part.

Alpha XS Range - Fanuc 21*i* TB Control

All Alpha XS lathes are fitted with a customized Fanuc control that gives you the option of manual or automatic operation via a simple key switch. In manual mode, the control employs the latest upgraded version of Colchester-Harrison's own "Alpha System" which is acclaimed by thousands of Alpha users to be the simplest and most shop floor friendly teach lathe in the world.

In automatic mode, the full strength of Fanuc's latest technology is brought into play with the Manual Guide *i* programming system. This conversational system has been completely revamped from previous generations to become an outstandingly powerful and comprehensive conversational programming system.

The combination of these two systems on one machine means that the Alpha XS is the most versatile and capable lathe ever produced.

It will do virtually anything you ask of it!

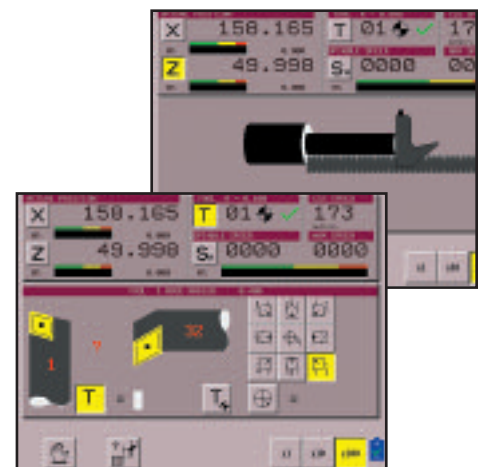
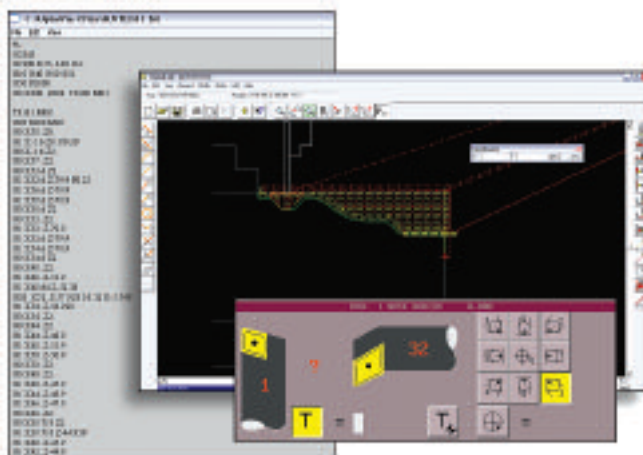

The Alpha System

Unique control software developed by our engineers to enable you to double, triple or even quadruple your productivity compared with other turning methods. The reason our Alpha System is so simple, practical and shop floor friendly is that our engineers are lathe specialists.

The Alpha System uses easily recognizable screen graphics along with simple question and answer prompts to guide you. It is also the reason that the Alpha System uses a touch screen, so you can work directly on screen rather than hunt for the right button to press.

Manual Turning

Turn the key and you are turning manually. It's as simple as that! The manual screen display shows X and Z positions just like a DRO plus spindle speed, tool number and feed rate.

Even if you haven't used a lathe since your schooldays you could walk up to an Alpha X now and cut metal.

The Ultimate Turning Machines

Standard Control Features for Alpha XS - Fanuc 21i - TB

- Ultra high speed 21i TB CNC
- 10.4" colour touch screen
- 4 Software systems
 - Colchester-Harrison "Alpha System"
 - Fanuc Manual Guide *i*
 - Industry standard ISO programming
 - CAD/CAM Machining (AlphaLink software)
- High speed fibre optic data transfer
- PCMCIA (flash card) and RS232 communication ports
- Twin MPG handwheels and rapid traverse joystick
- Tool nose radius compensation
- Tool wear / geometry offsets
- 32 pairs tool offsets
- Part program memory 64KB
- G10 programmable data input
- Toolpath graphics
- Thread cutting retract
- Continuous thread cutting
- Rigid tapping
- G code system B/C
- Custom macro B
- Chamfering macro & corner radius
- Inch/metric conversion
- Multi repetitive cycles I & II
- RS232 interface
- Background editing
- Machine alarm diagnostics
- Canned cycles for drilling
- Constant surface speed
- 3D graphic simulation
- Manual Guide *i*
- Spindle orientation
- Ethernet link
- 2 year GE Fanuc parts & labor warranty

ALPHA XS

Tool Setting

On many lathes tool setting can be a difficult and tedious process. No lathe control has a simpler tool setting procedure than the Alpha. Just follow the instructions on three screens and the job is done, with the machine automatically calculating offsets and workshifts for you. (These offsets will carry over to the manual guide *i* side).

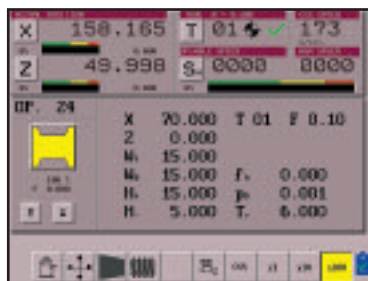

Semi-Automatic Turning

With the Colchester-Harrison Alpha System, a wealth of semi-automatic turning operations can be performed. These include parallel turning to stop positions, chamfers and radii, tapers, threads, grooves, box cycles and even contour shapes. These can be linked together to produce even the most complex of components quickly and efficiently.

What's more, the easy to understand shop floor language coupled with touch screen simplicity means that an operator can learn to machine parts quickly.

Most operators will learn to use the Alpha System in less than half a day!

One of the advantages of the Alpha System is that you are always in control of the machine and you can manually override machining at any time to gain confidence or to hit the optimum tool performance.

Manual Guide *i* for Alpha XS/MT/XM

Automatic Turning

Manual Guide *i* is the latest and most powerful conversational programming system from Fanuc. It offers the most comprehensive and feature laden aid that any lathe programmer could want, and becomes available, when the keyswitch on the control panel is turned to the automatic position.



Simulation and Animation

Manual Guide *i* has a more powerful graphics package than many commercial CAD/CAM systems. After a program has been created, a simulated component can be viewed in any direction, or as a 3D model that can be cut or sectioned or magnified to see detail.

This simulated component can then be animated to show the cutting process, the toolpath, metal removal and the finished component to ensure that what you get is what you have programmed and exactly what you want.



Customized Pages

Despite the enormous strength of the Manual Guide *i* system, our engineers have been able to bring their turning experience into play to develop Customized cycles especially for the needs of a manual/CNC type of lathes. These Colchester-Harrison developed cycles will save you a considerable amount of time and button pushing.

CNC Turning

The real strength of Manual Guide *i* is that it is effectively a CNC Graphical user interface. All the time you are working in Manual Guide *i*, the Fanuc control system is creating a CNC program in the background. This means that conversion from conversational mode to CNC mode is instant. It also means that you can work in either CNC or conversational mode or even both at the same time. Furthermore it means that industry standard CNC programs can be loaded into and out of the control at any time.

The Alpha XS is a powerful conversational lathe that can also run CNC programs developed elsewhere or to create CNC programs for use on other machines.



ALPHA/MT/XS/XM

The Ultimate Turning Machines

Creating A Program

1. Use the TOOL CALL AND START page
2. Call up roughing cycle
3. You will be prompted to enter roughing cutting information, speeds, feeds etc.
4. Follow the on screen instructions to draw your part
5. Store this shape as a part program
6. Use the toolchange cycle page for finishing tool
7. Call up finishing cycle
8. Enter finish cutting information
9. Call up saved shape
(there is no need to re enter shape information for finishing cut)
10. Finally use the customized cycle to part off and/or

ALPHA XS

CNC Standard Features

- Manual Guide *i*
- 10.4" (264mm) LCD color touchscreen
- MDI keyboard
- G10 offset value setting
- Graphic display
- PCMCIA data interface
- Manual handles X & Z axis
- 32 pairs of tool offsets
- Tool wear/geometry offsets
- 64k part program memory
- Tool nose radius compensation
- G code systems A, B, C
- Chamfering and corner radiusing
- Thread cutting retract
- Background editing
- Constant surface speed
- Canned drilling cycles
- Multi-repetitive cycles type I and II
- RS 232 interface
- Continuous thread cutting
- Rigid tapping
- Custom Macro B
- Inch/Metric Conversion
- Spindle orientation
- Ethernet

CNC Options

- Variable lead threading
- Additional part program memory 128k
- Stored stroke limit
- Direct drawing program
- Hours run/part count display
- Thread cutting retract

Alpha CNC4000XM - Fanuc 21i - TB

The award winning Colchester-Harrison Alpha CNC4000XM manual/CNC lathe is the first Alpha ever produced with the capability for high-precision C-axis milling as well as metal turning. Effectively 'two machines in one', this milling option builds on the features of the XS making it a highly versatile and cost-effective machine for a wide range of advanced machining applications, with full contouring capability and positional accuracy of +/- 0.01° it is already proving highly attractive to specialist engineering tool-rooms in many countries.



Driven Tooling for CNC4000XM Capto Toolpost (option)

The Capto toolpost is a totally modular system with quick change, 2 micron repeatability in a range of sizes to suit your application.

- Internal coolant supply
- 2 sizes (C6 & C5)
- Positive 3 way tooling
- Universal system for turning or milling
- Max. turned diameter 14.4" (366mm)
- 5hp
- 3000 rpm max.

Diplomatic Driven Tool Turret (option)

- Turret type Diplomatic BS-DT-16-240
- Disc Diameter 14.17" (360mm)
- Tool Holder PCP 4 driven tool stations @ (ø)9.44" (240mm)
4 fixed tool stations @ (ø)11.37" (289mm)
- Tool holder type 40VDI
- Total no. tools 8
- Total no. driven tools 4
- Max. turned diameter 12.40" (315mm)
- Drive 5hp
- Max. speed 6000 rpm

Alpha CNC6000XS/CNC7000XS

Weighing in at up to 8 tons, with 35hp (26 Kw) of power, all cast iron construction, the latest Fanuc control and the flexibility of Alphaslink and ISO programming systems this machine is perfect for applications in the Oil Industry, Defense, Aerospace and other Heavy Industries.

Designed to accept large diameter components the Alpha has a swing over bed of up to 40" (1000mm), a swing in gap of up to 51.18" (1300mm), spindle bore of up to 14.9" (380mm) and a center distance of up to 160" (4000mm).

MT/XS/XM



- Up to a 40" (1000mm) swing over bed
- 35hp (26 Kw) motor
- Alphaslink, MGI and ISO programming
- Gamet taper roller spindle bearings
- 1.57" (40mm) X axis precision ballscrews
- 2.48" (63mm) X axis precision ballscrews
- Full digital motors and drives
- Latest Fanuc 21i-TB control

The wide range of productivity enhancements available allow the Alpha CNC6000XS/CNC7000XS to be developed to your exact requirements. These options include a wide range of workholding and toolholding equipment, fixed and travelling steady rests, power chuck, auto indexing turrets and power operated tailstock amongst many others.

Tooling Systems for Alpha XT/XS/XM/MT

Indexing Quick Change Tool Post

High accuracy 40 position hand indexing 4 station toolpost with quick change toolholder.

	Model	Tool Section Sq Max	Max. Boring Bar Dia.	MT
Alpha CNC1000XT/MT/XS	Size 1	5/8"	5/8"	1, 2
Alpha CNC2000XT/MT/XS	Size 2	3/4"	3/4"	2, 3
Alpha CNC3000XT/MT/XS	Size 2	1"	1"	3, 4
Alpha CNC4000XT/MT/XS	Size 3	1-1/4"	1-1/4"	3, 4
Alpha CNC6000XS	Size 4	1-1/2"	1-1/2"	4, 5
Alpha CNC7000XS	Size 4	1-1/2"	1-1/2"	4, 5

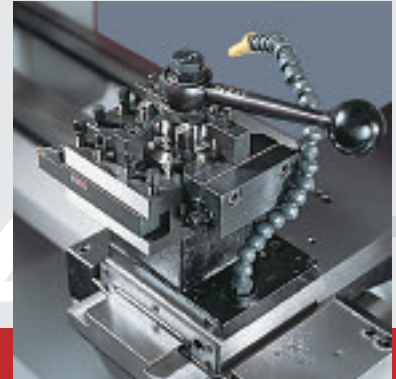

Automatic Bi-Directional Indexing Disc Turrets

Multi station VDI auto power turret mounted on the front of the cross slide.

	TOOLHOLDER SIZE	TOOL SECTION	MAX. BORING BAR DIA.	NO. OF STATIONS
Alpha CNC1000XT/XS/MT	VDI 30	3/4" (20mm)	1.26" (32mm)	8
Alpha CNC2000XT/XS/MT	VDI 30	3/4" (20mm)	1.26" (32mm)	8
Alpha CNC3000XT/XS/MT	VDI 30	3/4" (20mm)	1.26" (32mm)	8
Alpha CNC4000XT/XS/MT	VDI 40	1" (25mm)	1.57" (40mm)	8
Alpha CNC6000XS	VDI 50	1-1/4" (32mm)	1.96" (50mm)	8
Alpha CNC7000XS	VDI 50	1-1/4" (32mm)	1.96" (50mm)	8

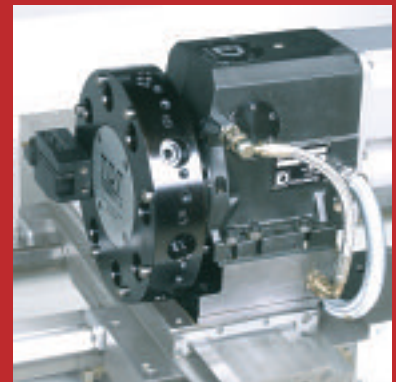

Standard Machine Features for Alpha XT/XS/XM/MT

- CE Regulated electrically interlocked machine guarding
- Stainless steel ballscrew cover
- AlphaLink CAD/CAM for windows
- AlphaLink instruction disc
- Hands-on tutorial disc
- Rapid traverse joystick
- Machine work light
- Electric coolant system
- Gamet ABEC 9 equivalent super high precision taper roller bearings
- Operation and spare parts manual
- Accuracy charts
- Wheeled swarf bin
- Automatic control oil pump slide-ways and ballscrew lubrication
- Automatic external oil pump head-stock lubrication
- External floor mounted transformer

Increase Your Productivity with the Optional 8-Station Automatic Turret with .45 sec. Index Time



Turret, Tooling Stroke and Traverse Dimensions

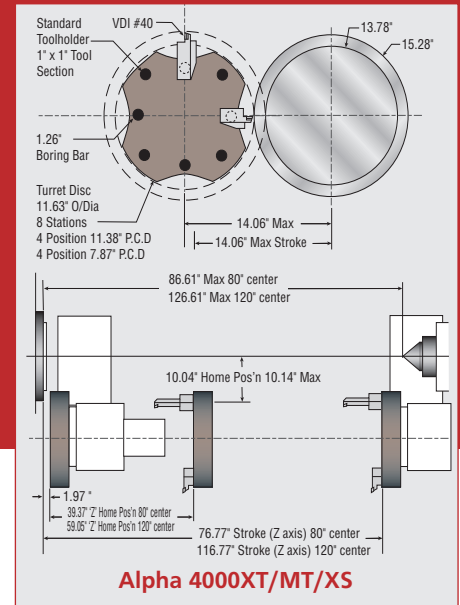
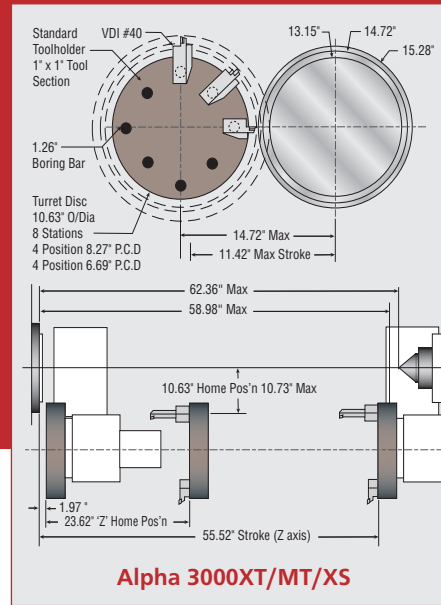
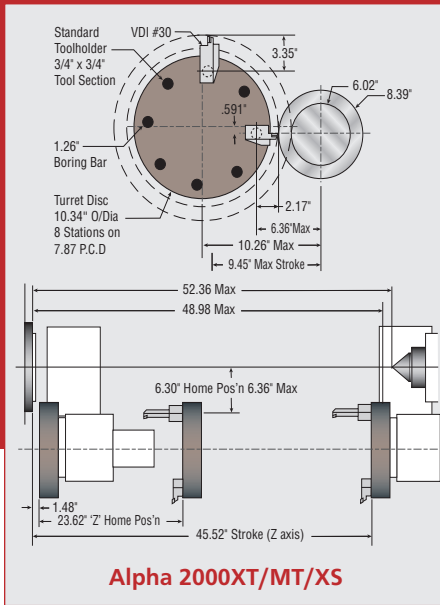

ALPHA SERIES

Machine Options

- Superior precision manual 3 & 4 jaw chucks and hydraulically operated 3 jaw chucks from Pratt Burnerd International
- Range of Crawford collet chucks and collets
- Range of fixed and travelling steadies
- Rotating centers
- Choice of manual or automatic tooling systems
- Workholding faceplate with guard
- Work driver plate
- High pressure coolant system (must be ordered with 8 station turret)

Alpha Series Tooling Dimensions

Alpha 1000XT/MT/XS Alpha 2000XT/MT/XS

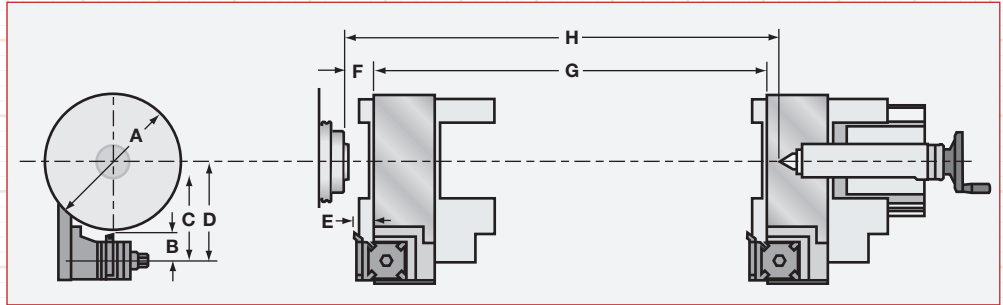

Model	Center	Spindle	A	B	C Stroke	D	E	F Min	G Stroke	H
Alpha 1000XT/XS/MT	25" (650mm)	D1-4	13.78" (350mm)	3.22" (82mm)	9.44" (240mm)	11.43" (290.5mm)	2.24" (57mm)	3.81" (97mm)	21.93" (557mm)	28.00" (711mm)
Alpha 2000XT/XS/MT	50" (1250mm)	D1-6	15.75" (400mm)	3.22" (82mm)	9.44" (240mm)	11.43" (290.5mm)	2.24" (57mm)	3.81" (97mm)	45.41" (1156mm)	50.47" (1282mm)

Alpha 3000XT/MT/XS Alpha 4000XT/MT/XS

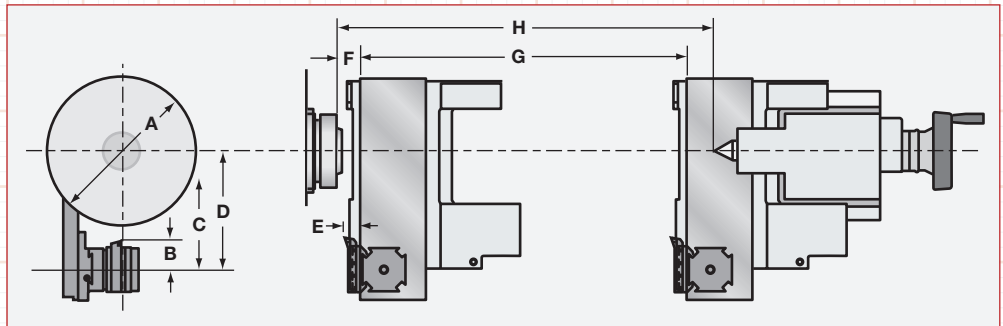

Model	Center	Spindle	A	B	C Stroke	D	E	F Min	G Stroke	H
Alpha 3000XT/XS/MT	60" (1500mm)	D1-8	18.11" (450mm)	3.54" (90mm)	11.41" (290mm)	14.44" (367mm)	1.69" (43mm)	2.79" (71mm)	59.44" (1510mm)	66.06" (1678mm)
Alpha 4000XT/XS/MT	80" (2000mm)	D1-11	21.81" (554mm)	3.54" (90mm)	11.41" (290mm)	14.44" (367mm)	1.69" (43mm)	2.44" (62mm)	79.13" (2010mm)	85.39" (2169mm)
Alpha 4000XT/XS/MT	120" (3000mm)	D1-11	21.81" (554mm)	3.54" (90mm)	11.41" (290mm)	14.44" (367mm)	1.69" (43mm)	2.44" (62mm)	118.5" (3010mm)	124.76" (3169mm)

Alpha 6000XS

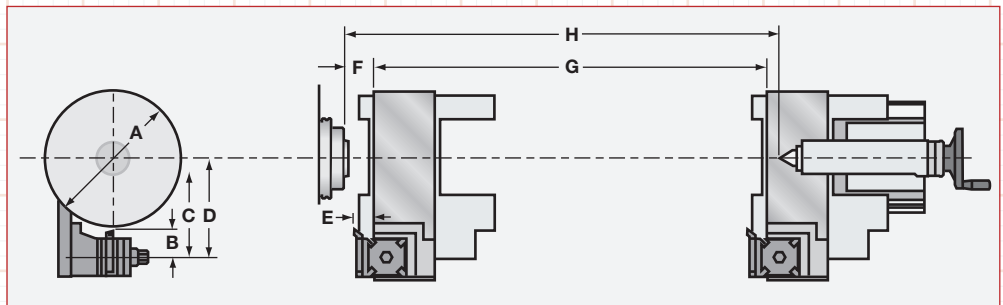

Model	Center	Spindle	A	B	C Stroke	D	E	F Min	G Stroke	H
Alpha 6000XS	80" (2000mm)	D1-11	25.59" (650mm)	5.56" (144mm)	15.74" (400mm)	18.81" (478mm)	2.99" (76mm)	2.40" (61mm)	74.01" (1880mm)	83.07" (2110mm)
Alpha 6000XS	120" (2000mm)	D1-11	25.59" (650mm)	5.56" (144mm)	15.74" (400mm)	18.81" (478mm)	2.99" (76mm)	2.40" (61mm)	113.38" (2880mm)	122.44" (3110mm)
Alpha 6000XS	160" (2000mm)	D1-11	25.59" (650mm)	5.56" (144mm)	15.74" (400mm)	18.81" (478mm)	2.99" (76mm)	2.40" (61mm)	152.75" (3880mm)	161.81" (4110mm)

Power Diagrams

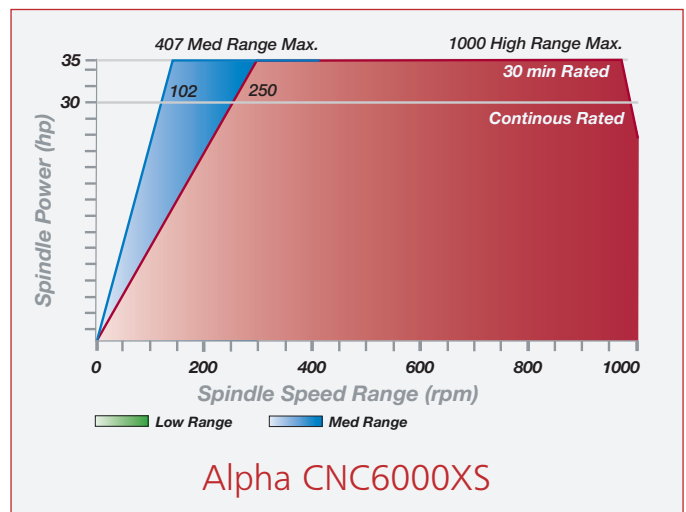
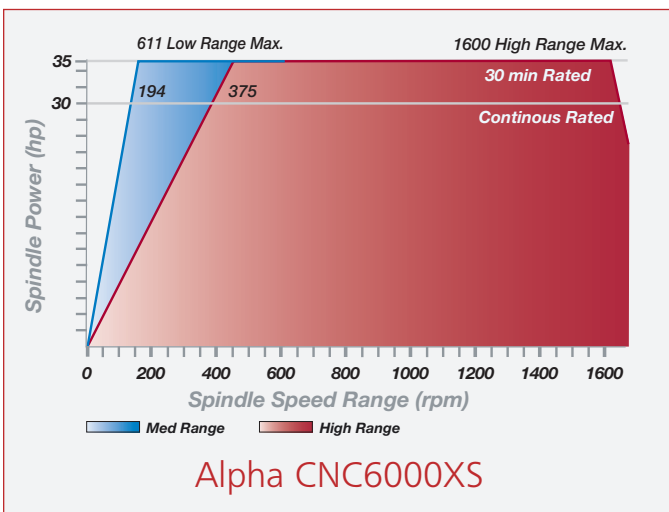
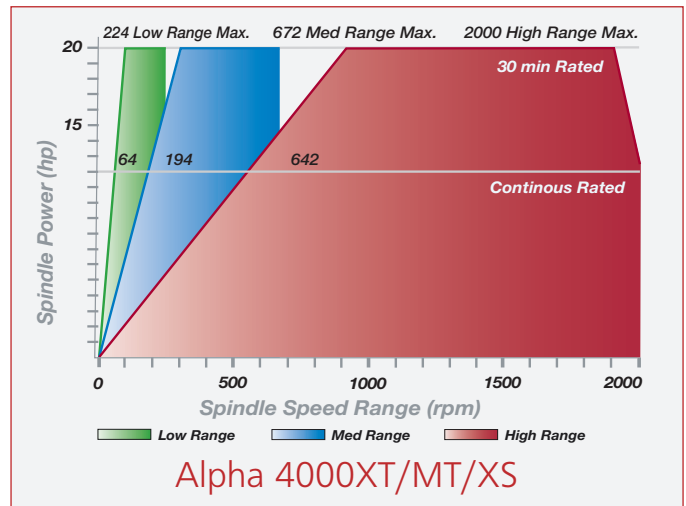
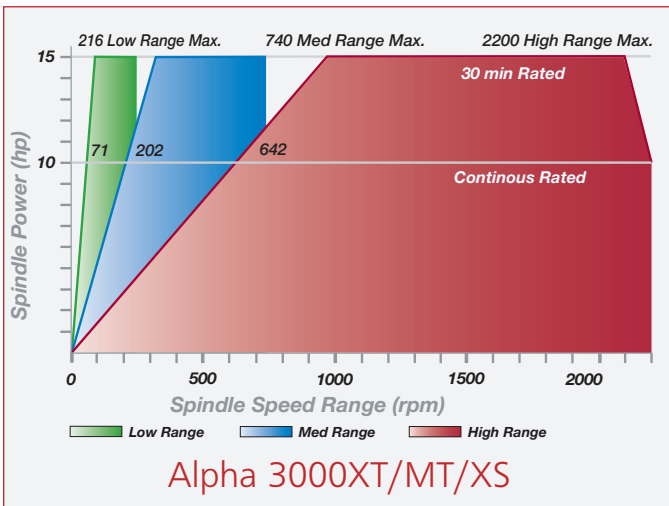
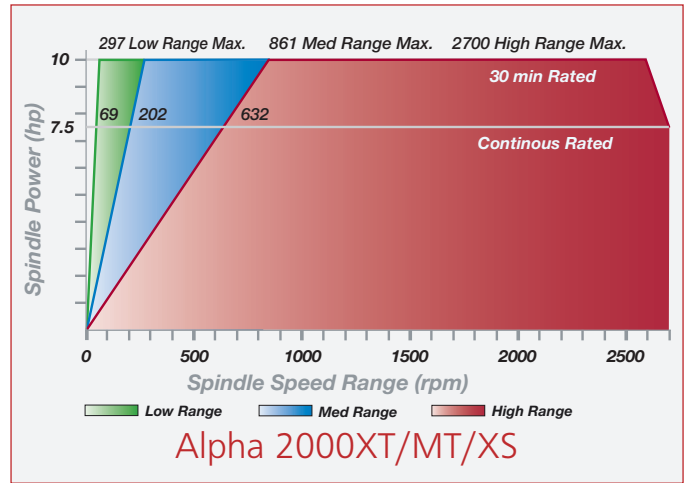
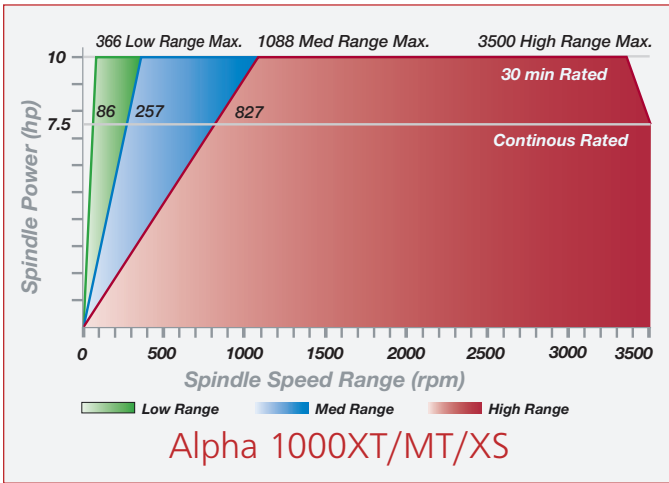

ALPHA SERIES

Specifications

Model	CNC1000XT/MT/XS	CNC2000XT/MT/XS	CNC3000XT/MT/XS
Capacity			
Swing over bed	13.7" (350mm)	15.7" (400mm)	18.1" (460mm)
Swing over cross slide	7.7" (196mm)	9.7" (246mm)	10.6" (270mm)
Swing in gap	21" (535mm)	23" (585mm)	28.7" (730mm)
Gap width in front of faceplate	6.5" (165mm)	6.5" (165mm)	8.5" (400mm)
Spindle center height from floor	42.7" (1080mm)	42.7" (1080mm)	45" (1143mm)
Construction			
Width of cross slide	7" (178mm)	7" (178mm)	8" (208mm)
Type of cross slide ways	Dovetail	Dovetail	Dovetail
Bed width	12.5" (320mm)	12.5" (320mm)	15.7" (400mm)
Depth of bed	15" (380mm)	15" (380mm)	18" (400mm)
Type of bed ways	V and flat ways	V and flat ways	V and flat ways
Coolant tank capacity	20 gallons (75 liters)	20 gallons (75 liters)	25 gallons (95 liters)
Spindle			
Spindle nose	D1-4	D1-6	D1-8
Spindle front bearing I.D.	2.756" (70mm)	3.685" (94mm)	5.25" (133mm)
Spindle taper	4MT	4MT	5MT
Spindle bore	1.63" (42mm)	2.16" (55mm)	3.07" (78mm)
Speed ranges automatically selected	3	3	3
Spindle speed - low range	1-366 rpm	1-297 rpm	1-247 rpm
Spindle speed - medium range	1-1088 rpm	1-861 rpm	1-740 rpm
Spindle speed - high range	1-3500 rpm	1-2700 rpm	1-2200 rpm
Spindle drive	Variable AC	Variable AC	Variable AC
Spindle motor (Continuous/30 min)	7.5/10 hp (5/7.5kW)	7.5/10 hp (5/7.5kW)	10/15 hp (7.5/11kW)
Minimum spindle speed for full power	56 rpm	69 rpm	71 rpm
Power consumption	22 KVA	22 KVA	26 KVA
Axis			
Cross slide travel (X axis)	9.65" (245mm)	9.65" (245mm)	11.7" (310mm)
X-axis rapid traverse	315"/min (8m/min)	315"/min (8m/min)	315"/min (8m/min)
X and Z-axis feed rate (inch)	.0012"-236"/rev.	.0012"-236"/rev.	.0012"-236"/rev.
X and Z-axis feed rate (mm)	.03"-60"/rev.	.03"-60"/rev.	.03"-60"/rev.
X-axis thrust (continuous)	915 lbs. (415kg)	915 lbs. (415kg)	1,464 lbs. (664kg)
X-axis ballscrew	20 x 4 mm	20 x 4 mm	25 x 4 mm
Saddle travel (Z axis)	21.9" (557mm)	45.5" (1156mm)	55.0" (1510mm)
Z-axis rapid traverse	394"/min (10m/min)	394"/min (10m/min)	394"/min (10m/min)
Z-axis thrust (continuous)	2,064 lbs. (936kg)	2,064 lbs. (936kg)	2,196 lbs. (996kg)
X-axis ballscrew	32 x 6 mm	32 x 6 mm	40 x 8 mm
Positioning accuracy	±0.0002" (.005mm)	±0.0002" (.005mm)	±0.0002" (.005mm)
Repeatability	±0.0001" (.0025mm)	±0.0001" (.0025mm)	±0.0001" (.0025mm)
Tailstock			
Tailstock taper	4MT	5MT	6MT
Tailstock quill diameter	2.48" (63mm)	2.87" (73mm)	3.74" (95mm)
Tailstock quill travel	5.51" (140mm)	5.51" (140mm)	5.70" (145mm)

Illustrations and specifications are not binding in detail. The designs are subject to modification and improvement without notice. Workpiece capacity and machinable lengths and diameters will vary and may be reduced below maximum depending on workholding and tooling used.

Not all the features described in the brochure are relevant to all machines in the range.
*HEAVY DUTY SINGLE GUARD INTERLOCKED TO THE SADDLE

**CNC4000/80XT/MT/XS
CNC4000/120XT/MT/XS**

21.8" (554mm)
14.5" (370mm)
32.7" (830mm)
8.5" (400mm)
47" (1194mm)

8" (208mm)
Dovetail
15.7" (400mm)
18" (400mm)
V and flat ways
25 gallons (95 liters)

D1-11
5.905" (150mm)
5MT
4.09" (104mm)
3
1-224 rpm
1-672 rpm
1-2000 rpm
Variable AC
10/15 hp (7.5/11kW)
64 rpm
26 KVA

11.7" (310mm)
315"/min (8m/min)
.0012"-236"/rev.
.03"-60"/rev.
1,464 lbs. (664kg)
25 x 4 mm
79.1"/118.5" (2010/3010mm)
394"/min (10m/min)
2196 lbs. (996kg)
40 x 8 mm
±0.0002" (.005mm)
±0.0001" (.0025mm)

6MT
3.74" (95mm)
5.70" (145mm)

**CNC4000/80XM
CNC4000/120XM**

21.8" (554mm)
14.5" (370mm)
32.7" (830mm)
8.5" (400mm)
47" (1194mm)

8" (208mm)
Dovetail
15.7" (400mm)
18" (400mm)
V and flat ways
25 gallons (95 liters)

D1-11
5.905" (150mm)
5MT
4.09" (104mm)
3
1-224 rpm
1-672 rpm
1-2000 rpm
Variable AC
10/15 hp (7.5/11kW)
64 rpm
26 KVA

11.7" (310mm)
315"/min (8m/min)
.0012"-236"/rev.
.03"-60"/rev.
1,464 lbs. (664kg)
25 x 4 mm
79.1"/118.5" (2010/3010mm)
394"/min (10m/min)
2196 lbs. (996kg)
40 x 8 mm
±0.0002" (.005mm)
±0.0001" (.0025mm)

6MT
3.74" (95mm)
5.70" (145mm)



**ALPHA
SERIES**

4000XM C Axis

Motor max torque	3ft/lbf (4Nm)
Output max torque	112ft/lbsf152Nm
Max output speed	105rpm
Resolution	0.001°

Specifications

Model	CNC6000/80XS CNC6000/120XS CNC6000/160XS	CNC7000/80XS CNC7000/120XS CNC7000/160XS
Capacity		
Swing over bed	31.50" (800mm)	40" (1000mm)
Swing over cross slide	20.47" (520mm)	27.9" (710mm)
Swing in gap	34.25" (870mm)	51.18" (1300mm)
Gap width in front of faceplate	13.38" (340mm)	15.35" (390mm)
Construction		
Width of cross slide	11.81" (300mm)	11.81" (300mm)
Type of cross slide ways	Dovetail	Dovetail
Type of bed ways	V and flat ways	V and flat ways
Spindle		
Spindle nose standard	D1-11	D1-11
Spindle bore standard	4.1" (105mm)	4.1" (105mm)
Spindle speed range standard	18-1400 rpm	18-1400 rpm
Spindle nose option #1	A2-11	A2-11
Spindle bore option #1	6.1" (155mm)	6.1" (155mm)
Spindle speed range option #1	18-1000 rpm	18-1000 rpm
Spindle nose option #2	A2-15	A2-15
Spindle bore option #2	9.8" (250mm)	9.8" (250mm)
Spindle speed range option #2	18-600 rpm	18-600 rpm
Spindle nose option #3	A2-20	A2-30
Spindle bore option #3	12" (305mm)	12" (305mm)
Spindle speed range option #3	18-400 rpm	18-400 rpm
Spindle nose option #4	A2-20	A2-30
Spindle bore option #4	14.9" (380mm)	14.9" (380mm)
Spindle speed range option #4	18-350 rpm	18-350 rpm
Speed ranges automatically selected	4	4
Spindle drive	Variable AC	Variable AC
Spindle motor (Continuous/30 min)	30/35 hp (22/26kW)	30/35 hp (22/26kW)
Minimum spindle speed for full power	56 rpm	69 rpm
Power consumption	32 KVA	32 KVA
Axis		
Cross slide travel (X axis)	21.6" (550mm)	21.6" (550mm)
X-axis rapid traverse - guards closed	196"/min (5000mm/min)	196"/min (5000mm/min)
X and Z-axis feed rate (inch)	.001-.024/rev	.001-.024/rev
X and Z-axis feed rate (mm)	.03-.6mm/rev	.03-.6mm/rev
X-axis ballscrew	1.57" (40mm)	1.57" (40mm)
Z-axis rapid traverse	393.7"/min (10000mm/min)	393.7"/min (10000mm/min)
Z-axis ballscrew	2.48" (63mm)	2.48" (63mm)
Positioning accuracy	±0.0002" (.005mm)	±0.0002" (.005mm)
Repeatability	±0.0001" (.0025mm)	±0.0001" (.0025mm)
Tailstock		
Tailstock taper	6MT	6MT
Tailstock quill diameter	4.13" (105mm)	4.13" (105mm)
Tailstock quill travel	10.8" (275mm)	10.8" (275mm)

Illustrations and specifications are not binding in detail. The designs are subject to modification and improvement without notice. Workpiece capacity and machinable lengths and diameters will vary and may be reduced below maximum depending on workholding and tooling used.

Not all the features described in the brochure are relevant to all machines in the range.
*HEAVY DUTY SINGLE GUARD INTERLOCKED TO THE SADDLE

Dimensions & Weights

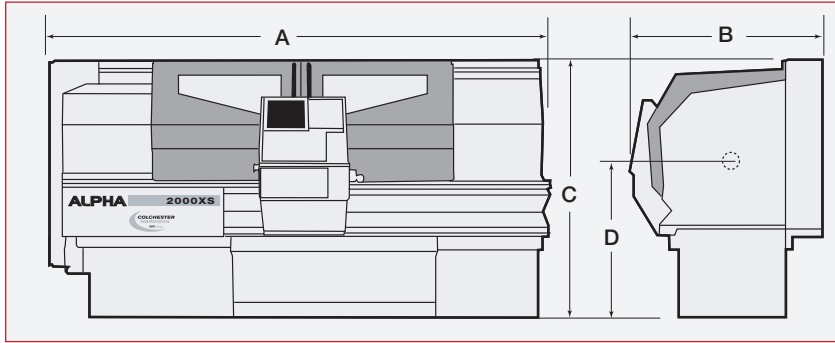

Model	Center	A	B	C	D	Weight
CNC1000XT	25" (600mm)	95" (2400mm)	67" (1700mm)	59" (1500mm)	42.7" (1080mm)	3968 lbs (1800kg)
CNC2000XT	50" (1250mm)	114" (2900mm)	67" (1700mm)	59" (1500mm)	42.7" (1080mm)	4850 lbs (2200kg)
CNC3000XT	60" (1500mm)	142" (3600mm)	79" (2000mm)	69" (1750mm)	45" (1143mm)	7054 lbs (3200kg)
CNC4000/80XT	80" (2000mm)	162" (4100mm)	79" (2000mm)	69" (1750mm)	47" (1194mm)	7937 lbs (3600kg)
CNC4000/120XT	120" (3000mm)	201" (5100mm)	79" (2000mm)	69" (1750mm)	47" (1194mm)	8818 lbs (4000kg)
CNC1000MT	25" (600mm)	95" (2400mm)	67" (1700mm)	59" (1500mm)	42.7" (1080mm)	3968 lbs (1800kg)
CNC2000MT	50" (1250mm)	114" (2900mm)	67" (1700mm)	59" (1500mm)	42.7" (1080mm)	4850 lbs (2200kg)
CNC3000MT	60" (1500mm)	142" (3600mm)	79" (2000mm)	69" (1750mm)	45" (1143mm)	7054 lbs (3200kg)
CNC4000/80MT	80" (2000mm)	162" (4100mm)	79" (2000mm)	69" (1750mm)	47" (1194mm)	7937 lbs (3600kg)
CNC4000/120MT	120" (3000mm)	201" (5100mm)	79" (2000mm)	69" (1750mm)	47" (1194mm)	8818 lbs (4000kg)
CNC1000XS	25" (600mm)	95" (2400mm)	67" (1700mm)	59" (1500mm)	42.7" (1080mm)	3968 lbs (1800kg)
CNC2000XS	50" (1250mm)	114" (2900mm)	67" (1700mm)	59" (1500mm)	42.7" (1080mm)	4850 lbs (2200kg)
CNC3000XS	60" (1500mm)	142" (3600mm)	79" (2000mm)	69" (1750mm)	45" (1143mm)	7054 lbs (3200kg)
CNC4000/80XS	80" (2000mm)	162" (4100mm)	79" (2000mm)	69" (1750mm)	47" (1194mm)	7937 lbs (3600kg)
CNC4000/120XS	120" (3000mm)	201" (5100mm)	79" (2000mm)	69" (1750mm)	47" (1194mm)	8818 lbs (4000kg)
CNC4000/80XM	80" (2000mm)	162" (4100mm)	79" (2000mm)	69" (1750mm)	47" (1194mm)	7937 lbs (3600kg)
CNC4000/120XM	120" (3000mm)	201" (5100mm)	79" (2000mm)	69" (1750mm)	47" (1194mm)	8818 lbs (4000kg)

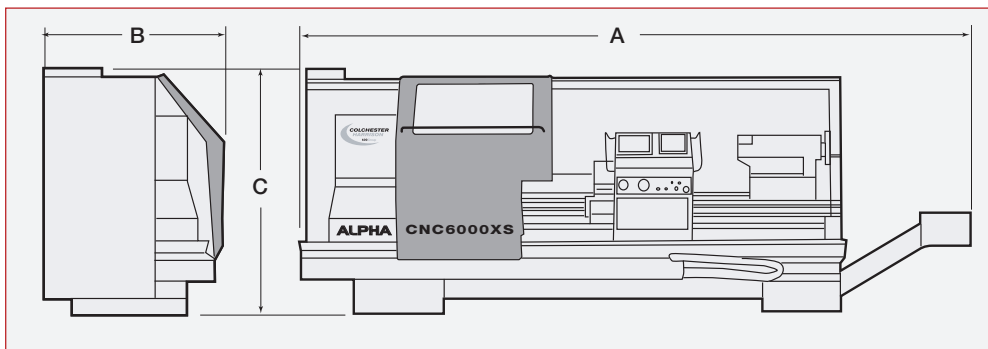

Model	Center	A	B	C	Net Weight	Gross Weight
CNC6000/80XS	80" (2000mm)	185" (4700mm)	89" (2250mm)	89" (2260mm)	11,023 lbs (5000kg)	12,566 lbs (5700kg)
CNC6000/120XS	120" (3000mm)	224" (5700mm)	89" (2250mm)	89" (2260mm)	13,668 lbs (6200kg)	15,432 lbs (7000kg)
CNC6000/160XS	160" (4000mm)	267" (6700mm)	89" (2250mm)	89" (2260mm)	16,314 lbs (6700kg)	18,519 lbs (6900kg)
CNC7000/80XS	80" (2000mm)	185" (4700mm)	89" (2250mm)	89" (2260mm)	11,023 lbs (5000kg)	12,566 lbs (5700kg)
CNC7000/120XS	120" (3000mm)	224" (5700mm)	89" (2250mm)	89" (2260mm)	13,668 lbs (6200kg)	15,432 lbs (7000kg)
CNC7000/160XS	160" (4000mm)	267" (6700mm)	89" (2250mm)	89" (2260mm)	16,314 lbs (6700kg)	18,519 lbs (6900kg)