

STORM

CNC Vertical Machining Center

VMC1020L/S



- 24 Tool Dual Arm ATC
- Linear or Square Ways
- 47.24" x 19.68" Table
- 40"x20"x22" X/Y/Z Travel
- 20/15 hp Spindle Motor
- 10,000 rpm with Oil Cooler

VMC1020 Spindle Power Chart

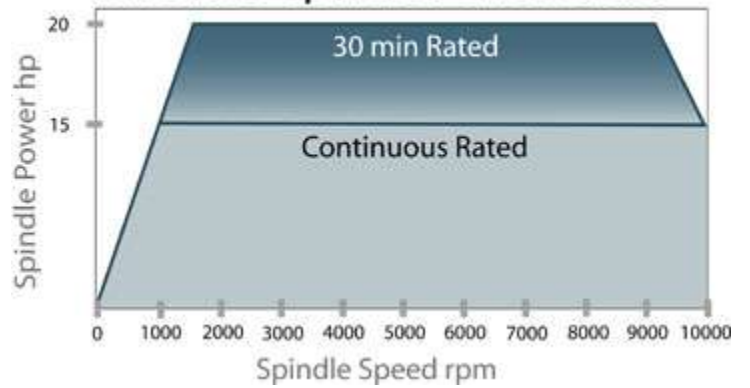

Model	VMC1020L/S
Table	
Dimensions	47.2" x 19.7" (1200 x 500mm)
Number of T-slots	5
T-slot width	.71" (18mm)
T-slots center	3.94" (100mm)
Table load	2,200 lbs. (1000kg)
Work Travels	
X axis (long.) Linear Ways	40.15" (1020mm)
X axis (long.) Square Ways	40.15" (1020mm)
Y axis (cross)	20" (510mm)
Z axis (vertical)	22" (560mm)
Spindle nose to table	
Linear Ways	5.9"-27.94" (150-710mm)
Square Ways	5.7"-27.74" (145-705mm)
Spindle center to column	
Linear Ways	24.1" (608mm)
Square Ways	22.6" (575mm)
Way dimensions	
Linear Ways	1.38" (35mm)
Square Way Width	4.33" (110mm)
Table center to column	
Linear Ways	13.89"(353mm)-33.98"(863mm)
Square Ways	12.6"(320mm)-32.7"(830mm)
Ballscrew dia./pitch	1.57"(40mm)/.47"(12mm)
Spindle	
Spindle Motor (Cont./30 min.)	15/20 hp (11/15kw)
Spindle taper	CAT #40
Spindle speed	10,000 rpm
Option #1 spindle speed	12,000 rpm
Option #2 spindle speed	8000 rpm
Option #3 spindle speed	6000 rpm
Feed Rates	
Rapid traverse Linear Ways	1417 in/min (36m/min)
Rapid traverse Square Ways	945 in/min (24m/min)
Cutting feed rate	.4-393 in/min(10m/min)
Auto Tool Changer	
Number of tools	24 Dual Arm
Tool to tool	2.5 sec.
Max. tool dia.	7.08" (180mm)
Max. tool length	11.81" (300mm)
Max. tool weight	17.6 lbs. (8kg)
Tool shank	CAT #40
Miscellaneous	
Coolant pump	1 hp (.75kw)
X/Y/Z axes servo motor	4 hp (3kw)
Air pressure	85 psi
Lubrication	Auto Oil
Total KVA (3 axes/4 axes)	25/30 KVA
Machine Accuracy	
Positioning	±.0002" (.005mm)
Repeatability	±.0001" (.0025mm)
Weight	
Weight Linear Ways	11,023 lbs (5000kg)
Weight Square Ways	11,464 lbs (5200kg)

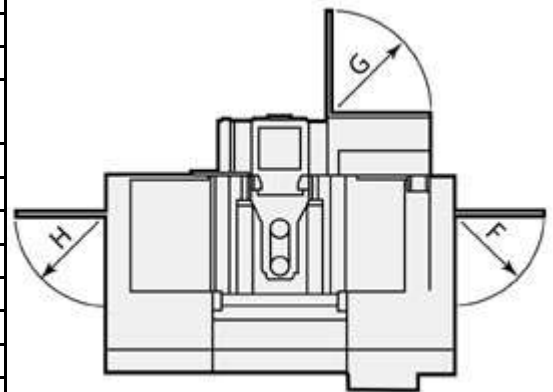
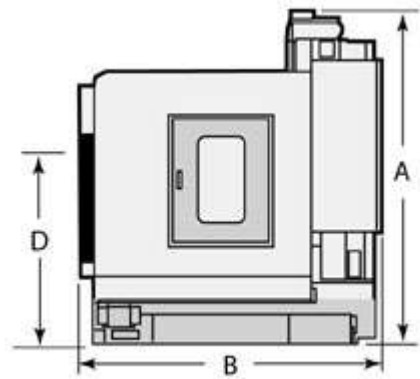

Model	VMC1020
Height A	112" (2840mm)
Width B	87" (2210mm)
Length C	115" (2900mm)
Control Ht. D	63" (1600mm)
F	28" (708mm)
G	33" (831mm)
H	28" (708mm)
Table	
J	19.7" (500mm)
K	47.2" (1200mm)
L	1.96 (50mm)
M	3.94" (100mm)
No. of T-slots	5

(Specifications and design are subject to change without notice or obligation.)

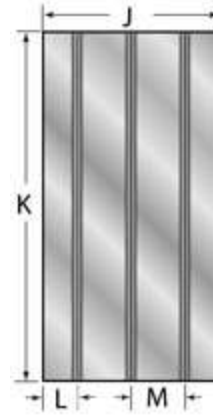

Specifications and design are subject to change without notice or obligation.